

General Description

Series ZDR pilot operated pressure reducing valves are designed for maximum flow rates.

The reducing function can be located in the ports P, A or B. The sizes NG06 and NG10 are equipped with an integral return flow check valve (reducing function in A or B).

B



ZDR-P01

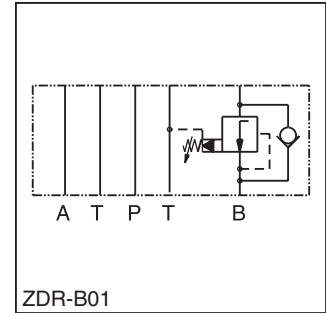

ZDR-B01

Features

- High flow capacity.
- Sizes:
 - ZDR01 – NFPA D03 / NG6 / CETOP 3
 - ZDR02 – NFPA D05 / NG10 / CETOP 5
- With integral return flow check valve.

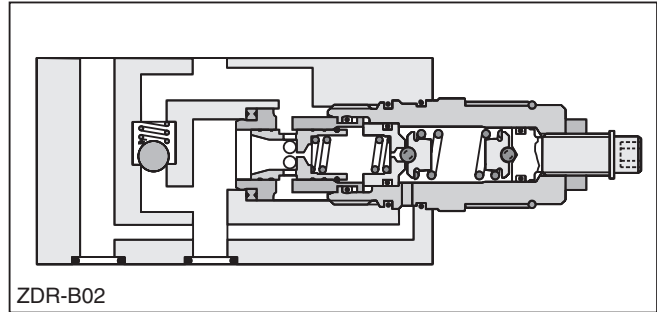

ZDR-B02

Specifications

General		
Size	NG6	NG10
Mounting Interface	DIN 24340 A6 ISO 4401 NFPA D03 CETOP RP 121	DIN 24340 A10 ISO 4401 NFPA D05 CETOP RP 121
Mounting Position	Unrestricted	
Ambient Temperature Range	-20°C to +50°C (-4°F to +122°F)	
Hydraulic		
Maximum Operating Pressure	up to 350 Bar (5075 PSI); ZDR-AR / BR up to 315 Bar (4568 PSI)	
Nominal Flow	80 LPM (21.2 GPM)	120 LPM (31.7 GPM)
Pilot Oil	0.2 LPM (0.1 GPM)	0.3 LPM (0.1 GPM)
Fluid	Hydraulic oil as per DIN 51524 ... 51525	
Fluid Temperature	-20°C to +80°C (-4°F to +176°F)	
Viscosity	Permitted	10 to 650 cSt / mm ² /s (46 to 3013 SSU)
	Recommended	30 cSt / mm ² /s (139 SSU)
Filtration	ISO Class 4406 (1999) 18/16/13 (acc. NAS 1638: 7)	

WARNING: This product can expose you to chemicals including Lead, Nickel (Metallic), or 1,3-Butadiene which are known to the State of California to cause cancer, and Lead or 1,3-Butadiene which is known to the State of California to cause birth defects and other reproductive harm. For more information go to www.P65Warnings.ca.gov.

Ordering Information

ZDR Pressure Reducing Valve	Port Option	Size	Pressure Range	S0 Hexagon Screw with Lock Nut	D Design Series	Seal
---------------------------------------	--------------------	-------------	-----------------------	--	---------------------------	-------------

Code	Description
01	NFPA D03 / NG6
02	NFPA D05 / NG10

Code	Description
1	up to 100 Bar (1450 PSI)
5*	up to 350 Bar (5075 PSI)

* AR/BR 325 Bar (4568 PSI)

Code	Description
1	Nitrile
5	Fluorocarbon

Code	Size	Description
P	01/02	Pressure reducing in P with pressure gauge port M
AR	01/02	Pressure reducing in A with check valve
BR	01/02	Pressure reducing in B with check valve

Weight: ZDR-P	ZDR-AR/BR
ZDR*01 1.6 kg (3.5 lbs.)	1.8 kg (4.0 lbs.)
ZDR*02 2.9 kg (6.4 lbs.)	3.0 kg (6.6 lbs.)



ZDR01

Pressure reducing in P with pressure gauge port M

Series
ZDRP011S0D1
ZDRP015S0D1

Pressure reducing in A with check valve

Series
ZDRAR011S0-D1
ZDRAR015S0-D1

Pressure reducing in B with check valve

Series
ZDRBR011S0D1
ZDRBR015S0D1

1 = 7 ... 140 Bar (102 ... 1450 PSI)
 5 = 7 ... 315 Bar (102 ... 4568 PSI)

ZDR02

Pressure reducing at P with pressure gauge port M

Series
ZDRP021S0D1
ZDRP025S0D1

Pressure reducing at A (with check valve)

Series
ZDRAR021S0D1
ZDRAR025S0D1

Pressure reducing at B (with check valve)

Series
ZDRBR021S0D1
ZDRBR025S0D1

Performance Curves

ZDR-P/AR/BR01

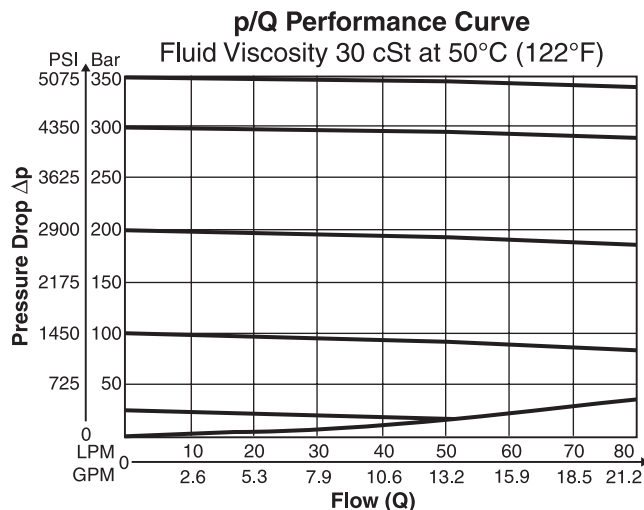

ZDR-P/AR/BR02

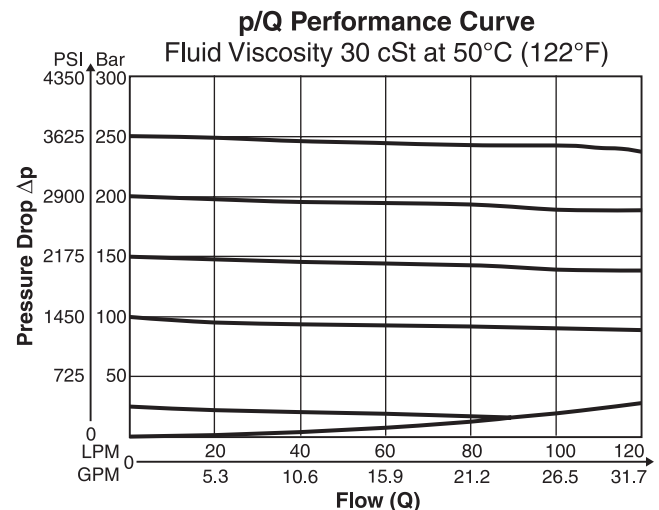

ZDR01 — Inch equivalents for millimeter dimensions are shown in (**)

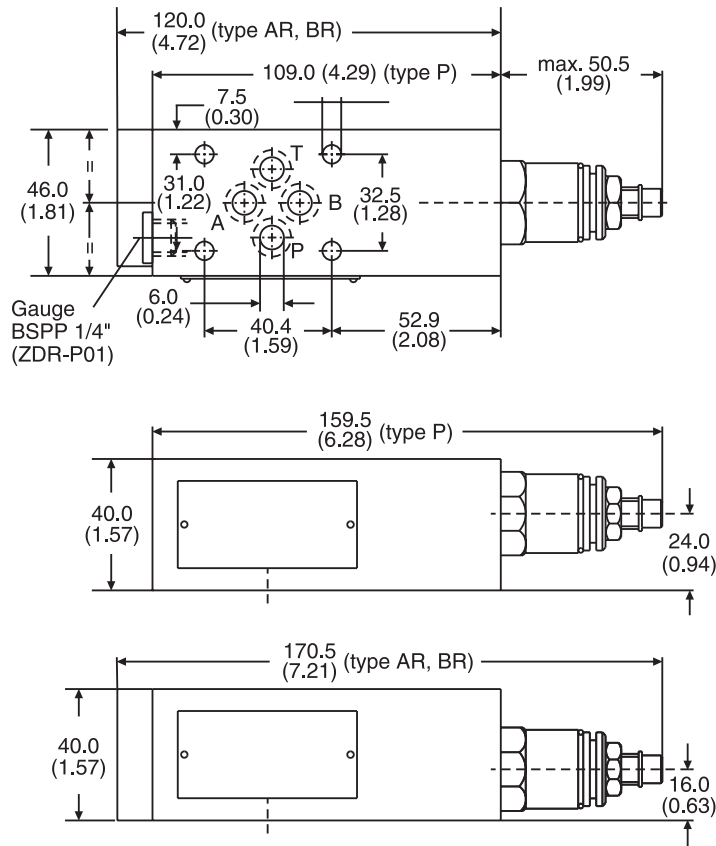

Seal Kit	
Seal	Order Code
1	098-91184-0
5	098-91185-0
Complete Cartridge	
Seal	Order Code
1	098-91102-0
5	098-91103-0

ZDR02 — Inch equivalents for millimeter dimensions are shown in (**)

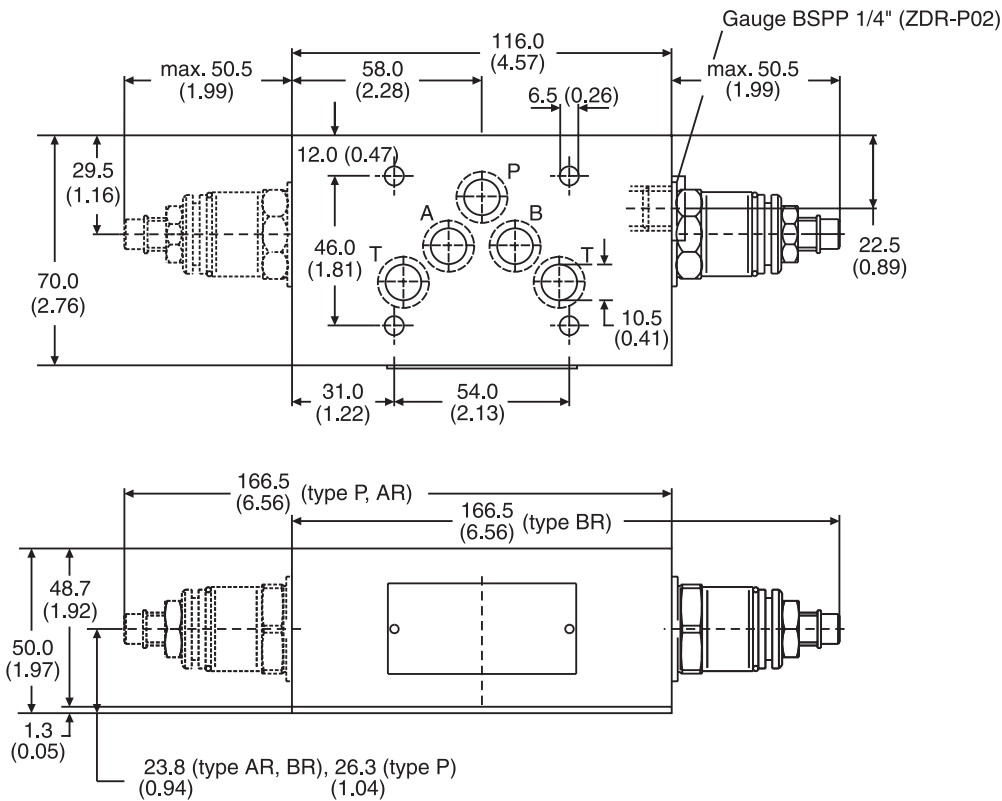

Seal Kit	
Seal	Order Code
1	098-91182-0
5	098-91183-0
Complete Cartridge	
Seal	Order Code
1	098-91102-0
5	098-91103-0

B